

HYBRID SERVO DRIVER ES-D808



FEATURES:

- Closed-loop, eliminates loss of synchronization
- Broader operating range – higher torque and higher speed
- Reduced motor heating and more efficient
- Smooth motion and super-low motor noise
- Does not need a high torque margin
- No Tuning and always stable
- Fast response, no delay and almost no settle time
- High torque at starting and low speed, high stiffness at standstill
- Lower cost

The HBS series offers an alternative for applications requiring high performance and high reliability when the servo was the only choice, while it remains cost-effective. The system includes a 2-phase stepper motor combined with a fully digital, high performance drive and an internal encoder which is used to close the position, velocity and current loops in real time, just like servo systems. It combines the best of servo and stepper motor technologies, and delivers unique capabilities and enhancements over both, while at a fraction of the cost of a servo system.

GENERAL SPECIFICATIONS:

Electrical Specifications (T_j = 25°C/77°F)

Parameters	ES-D808			
	Min	Typical	Max	Unit
Output current	0.5	-	8.2 (Peak)	A
Input voltage	24	48	80	VDC
Logic signal current	7	10	16	mA
Pulse input frequency	0	-	200	kHz
Microstep resolution	200		40000	steps / rev
Isolation resistance	500			MΩ

CONNECTOR CONFIGURATION:

The ES-D808 has four connectors, connector for control signals connections, connector for stator signal connections, connector for encoder feedback and connector for power and motor connections.

HYBRID SERVO DRIVER ES-D808

Control Signal Connector – Screw Terminal

Pin	Name	I/O	Description
1	PUL+	I	<p><u>Pulse signal:</u> In single pulse (pulse/direction) mode, this input represents pulse signal, each rising or falling edge active (software configurable, see hybrid servo software operational manual for more detail); In double pulse mode (software configurable), this input represents clockwise (CW) pulse, active both at high level and low level. 4-5V when PUL-HIGH, 0-0.5V when PUL-LOW. For reliable response, pulse width should be longer than 10µs. Series connect resistors for current-limiting when +12V or +24V used. The same as DIR and ENA signal.</p>
2	PUL-	I	
3	DIR+	I	<p><u>Direction Signal:</u> In single-pulse mode, this signal has low/high voltage levels, representing two directions of motor rotation. In double-pulse mode (software configurable), this signal is counter-clock (CCW) pulse, active both at high level and low level. For reliable motion response, DIR signal should be ahead of PUL signal by 5µs at least. 4-5V when DIR-HIGH, 0-0.5V when DIR-LOW. Please note that rotation direction is also related to motor-driver wiring match. Exchanging the connection of two wires for a coil to the driver will reverse motion direction. The direction signal's polarity is software configurable.</p>
4	DIR-	I	
5	ENA+	I	<p><u>Enable signal:</u> This signal is used for enabling/disabling the driver. In default, high level for enabling the driver and low level for disabling the driver (@ NPN control signal). Usually left UNCONNECTED (ENABLED). Please note that PNP and Differential control signals are on the contrary, namely low level for enabling. The active level of ENA signal is software configurable.</p>
6	ENA-	I	

Stator Signal Connector – Screw Terminal

Pin	Name	I/O	Description
1	INP+	O	<p><u>In-position Signal:</u> OC output signal; active when the difference between the actual position and the commanded position is zero. This port can sink or source 20mA current at 24V. The resistance between Pend+ and Pend- is high when active.</p>
2	INP-	O	
3	ALM+	O	<p><u>Alarm Signal:</u> OC output signal, active when one of the following protection is activated: over-voltage, over current and position following error. This port can sink or source 20mA current at 24V. In default, the resistance between ALM+ and ALM- is low impedance in normal operation and becomes high when the drive goes into error. The active level of alarm signal is software configurable. See Easy servo software operational manual for more details.</p>
4	ALM-	O	

Encoder Feedback Connector – Screw Terminal

Pin	Name	I/O	Description
1	EB+	I	Encoder channel B+ input
2	EB-	I	Encoder channel B- input
3	EA+	I	Encoder channel A+ input
4	EA-	I	Encoder channel A- input
5	VCC	O	+5V @ 100 mA max.
6	EGND	GND	Signal ground

Encoder Extension Cable Wire Out

Wire	Color	Name	Description	Wire	Color	Name	Description
1	Red	VCC	+5V power input	4	Blue	A-	Encoder Channel A-
2	White	GND	+5V GND	5	Yellow	B+	Encoder Channel B+
3	Black	A+	Encoder Channel A+	6	Green	B-	Encoder Channel B-

HYBRID SERVO DRIVER ES-D808

Power and Motor Connector – Screw Terminal			
Pin	Name	I/O	Description
1	A+	O	Motor Phase A+
2	A-	O	Motor Phase A-
3	B+	O	Motor Phase B+
4	B-	O	Motor Phase B-
5	+V	I	Power Supply Input (Positive), 30-72 VDC recommended, leaving rooms for voltage fluctuation and back-EMF.
6	GND	GND	Power Ground (Negative)

RS232 Communication Port			
Pin	Name	I/O	Description
1	NC	-	Not connected.
2	+5V	O	+5V power output
3	TxD	O	RS232 transmit.
4	GND	GND	Ground.
5	RxD	I	RS232 receive.
6	NC	-	Not connected.

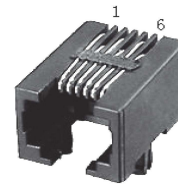

TYPICAL CONNECTIONS:

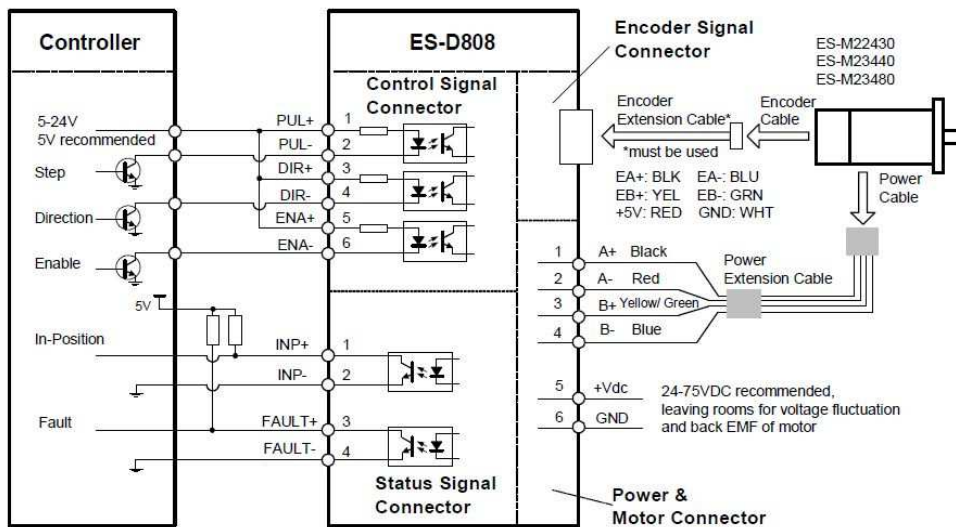
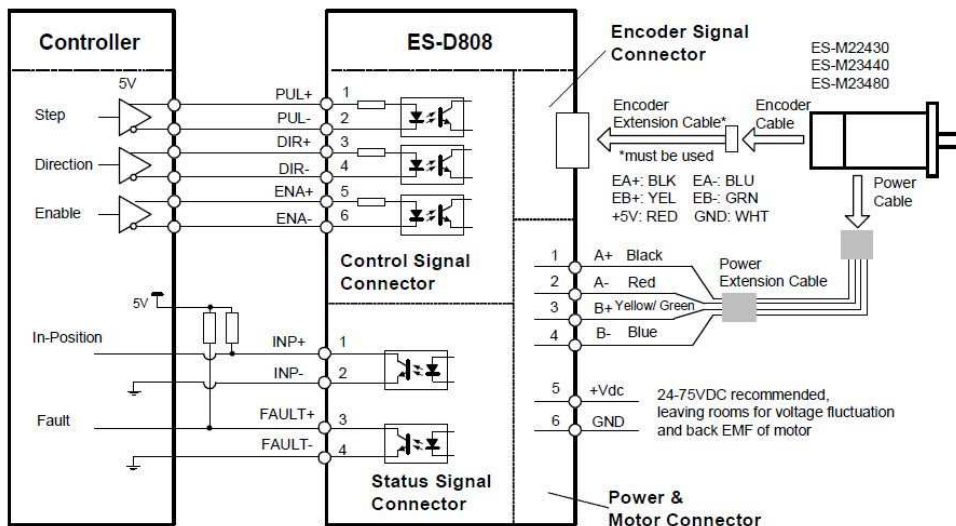

HYBRID SERVO DRIVER ES-D808

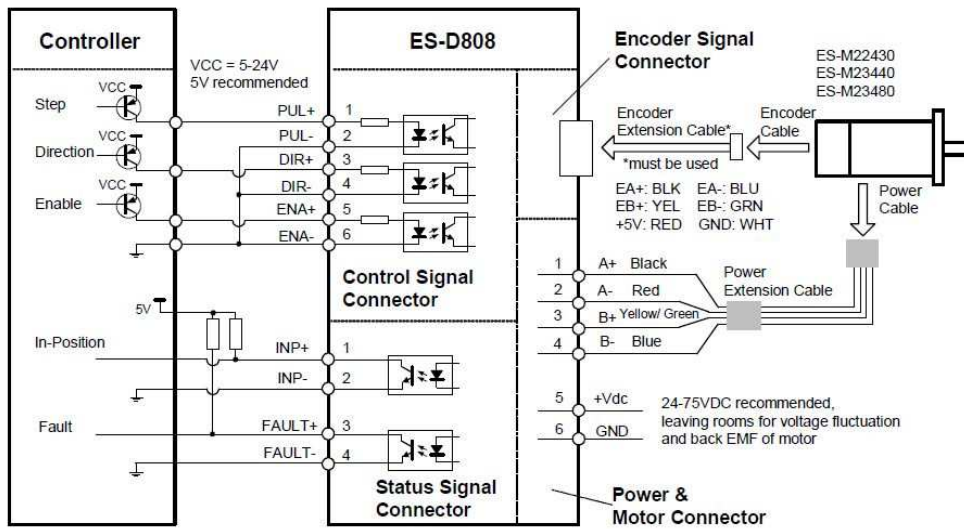

Connection to controller with sourcing output (PNP control signal)

MECHANICAL SPECIFICATIONS (unit: mm):

